

theben

RAMSES

RAMSES 856 top2 OT
Heating controller
8569132

Installation and operating guide

OT Box RAMSES top2 OT – Standard box



309560 04

GB



RAMSES 856 top2

Contents

Proper use	2
Disposal	2
Safety advice	3
Installation and dismantling	3
Connection	4
Terminal layout	5
Description	6
Start-up with RAMSES 850 top2 OT	7
Set TSP parameters (Transparent Slave Parameters)	8
Set heating curve of second heating circuit on controller	8
Systems/Applications 1–5	9
System 1	10
System 2	11
System 3	12
System 4	13
System 5 – comfort box	14
Switch chimney sweep function on/off	17
Operating hours counter	17
Connect USB/GSM modem	17
Error messages	18
Technical data	19
Service address/Hotline	20

Proper use

The heating controller RAMSES 856 top OT consists of the OT-Box RAMSES top2 OT as well as the room thermostat RAMSES 850 top2 OT, which transmits the values (target/actual values) via the Open-Therm bus. The 7-channel regulator regulates 2 heating circuits with the required circulation pumps and temperature sensors. In addition, the domestic hot water circulation is maximised via program control with optional legionella protection function. The range of functions can be extended via connection of 2 OT boxes.

- The device is intended for wall installation in the boiler room
- Corresponds to Type 1 B in accordance with IEC/EN 60730-1
- The entire system serves the purpose of digital heating regulation for time-dependent monitoring and control of room temperature (by means of circulation pumps, burner and/or motor mixing valve)
- It is used in dry rooms with normal levels of domestic cleanliness
- The controller is suitable only for the Heating-systems listed. For use in connection with other systems, contact the service department of Theben AG
- **Accessories:** optional: RAMSES 850 top2 OT (8509132), feed temperature sensor (9070371), plunge sensor (9070379), floor sensor (9070321), external temperature sensor (9070459), additional OT box for system 5 (standard box 9070712)

Disposal

Dispose of equipment in an environmentally sound manner

Safety advice



! WARNING

Danger of death through electric shock or fire!

- Installation should only be carried out by a qualified electrician!

- Use correct type of fuse for external fuse!
Overload leads to destruction of the relay.
- Avoid excessive heat generation.

Installation

- Remove baffle.
- Unlock and remove upper part of OT box RAMSES top2 OT by turning the bayonet socket 90° anti-clockwise.
- Attach base of the OT Box RAMSES top2 to the wall with enclosed material.
- Click terminal into the terminal support and connect cable with the OT connection terminals.
- Power supply line of the OT bus, attach the outputs and sensors in accordance with the selected connection diagram to the connection terminals of the base (see connection diagram on page 9).

- Put on upper part of the OT-Box RAMSES top2 OT, click in and secure with bayonet socket.
- Afterwards optionally click in baffle or RAMSES 850 top2 OT in opening.
- Connect OT-Box RAMSES top2 to power supply.

Dismantling

- Remove RAMSES 850 top2 OT or screen.
- Use a screwdriver to unlock upper part, remove and open device. If necessary take base from wall.

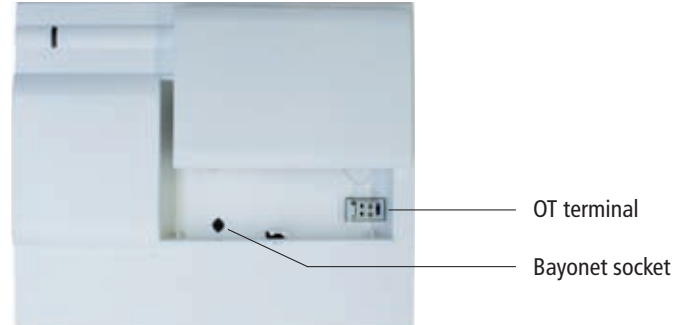

Connection



Danger of death through electric shock!

- Must be installed by qualified electrician!
 - Disconnect power source.
 - Cover or shield any adjacent live components.
 - Ensure device cannot be switched on!
 - Check power supply is disconnected.
 - Earth and bypass.
-
- Connect all consuming equipment (pumps, etc.) and sensors.
 - Connect RAMSES 850 top2 OT via OT interface.
 - Connect mains power between (L) (N) (terminal ①).

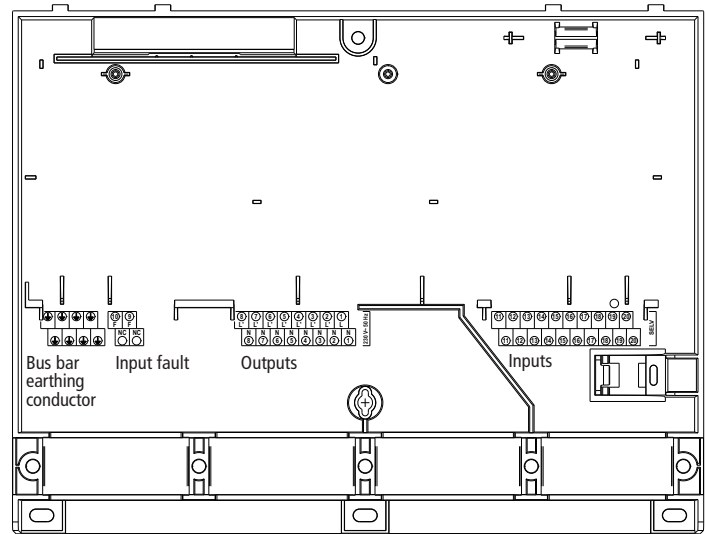

Inputs and outputs of the OT Box RAMSES top2 OT

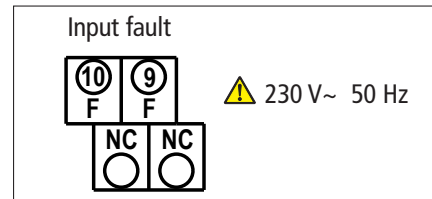

Terminal layout

Power connection ①

Outputs

- Heating circuit 1 pump as relay output ⑧
- Heating circuit 2 pump as relay output ⑦
- Burner as relay output ⑥
- Mixer closed (or 2nd burner stage) as relay output ⑤
- Mixer closed (or 2nd burner stage) as relay output ④
- Pump for domestic hot water feed as relay output ③
- Pump for domestic hot water circulation as relay output ②

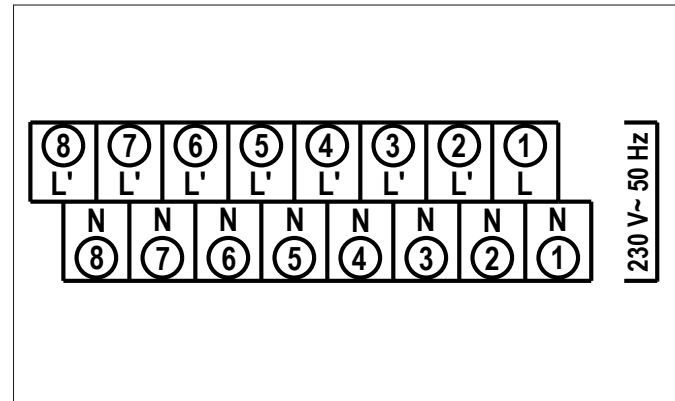

Inputs



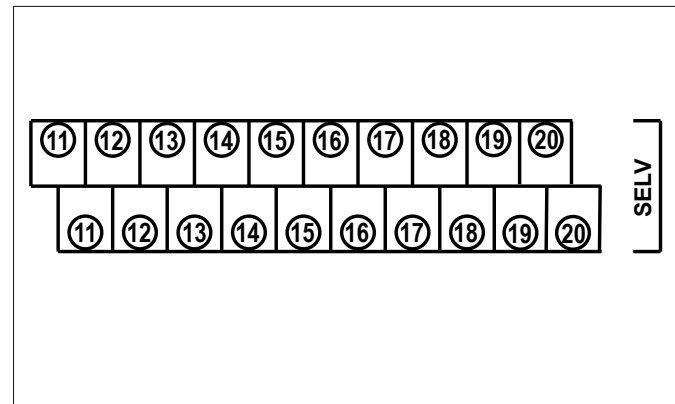







- Input fault ⑨ ⑩ (see page 4)
- OpenTherm-Slave (Connection RAMSES 850 top2 OT) ⑬
- OpenTherm-Master (Connection of second OT-Box) ⑭
- Domestic hot water temperature sensor ⑮
- Feed temperature sensor (mixer circuit) ⑰
- Boiler temperature sensor ⑱
- External temperature sensor ⑲
- Domestic hot water return temperature sensor (controls circulation pump) ⑳



The connected devices or sensors must be suitable for SELV or marked with protection class III.

⑪ ⑫ ⑮ not used

Description

- ①  LED for operating state OpenTherm
- ②  LED for pump 1
- ③  LED for pump 2
- ④  LED for burner (or error)
- ⑤  LED for mixer open
- ⑥  LED for mixer closed
- ⑦  LED for domestic hot water (DHW) feed
- ⑧  LED for domestic hot water (DHW) circulation
- ⑨  Button for switching outputs
(for test function without RAMSES 850 top2 OT)
- ⑩  Button and LED for chimney sweep function



Start-up with RAMSES 850 top2 OT



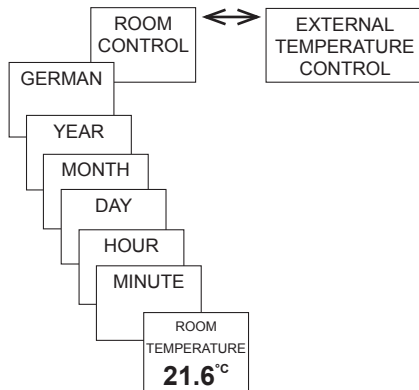

➤ After connection, the messages follow in the display (see image).

Language, room controls or OT controls, date, time and summer/winter time can be set in the MODE menu under TIME/DATE or SERVICE.

To set other functions, see operating manual for RAMSES 850 top2 OT.



- The OT box RAMSES top2 can be adapted for the particular heating system (5 systems) by setting different applications.
- The selection “Weather or room-dependent control” is made via the sensor connection. If an ambient temperature sensor is connected, it will be automatically detected and weather-dependent control will be carried out.
- All applications have a pump protection function.
- Almost all functions are controlled and displayed via RAMSES 850 top2 OT. The following messages are displayed:

-  HC Pump on
-  Burner on/off
-  Domestic hot water preparation on
-  Weather-dependent control

Set TSP parameters (Transparent Slave Parameters)

The TSP parameters are set in the SETTINGS menu.

- Confirm **TSP-PARAMETER** with **OK**.
15 parameters can be set (see below).
Parameter 0 includes the 5 systems/applications.
- Use **+** or **-** keys or rotary control to enter the value and confirm by pressing **OK**.
The value is transferred to the OT Box RAMSES top2 OT.

15 parameters are available from 0–14:

- 0 System selection (1, 2, 3, 4, 5 → default 1)
- 1 Boiler base temperature (10 ... 50 degrees, default 10 = off)
- 2 Max. feed temperature main circuit
(30 ... 90 degrees, default 80)
- 3 Max. feed temperature auxiliary circuit (rear mixer)
(30 ... 90 degrees, default 40)
- 4 Boiler hysteresis (1 ... 15 K, default 5)
- 5 Domestic hot water hysteresis (1 ... 10 K, default 5)
- 6 Domestic hot water priority / parallel operation (default ...)
- 7 Domestic hot water pump switch-off delay (0 ... 20 mins,
default 10)
- 8 Domestic hot water for frost protection (default ...)
- 9 Time for domestic hot water circulation pump:

- 0: Domestic hot water circulation pump only runs when temperature-controlled
- 0–99: Domestic hot water circulation pump via ΔT on, Value is the maximum runtime in s
- 10 Pump protection time (0 .. 11 pm, default 12)
- 11 Pump protection duration in s (0...99, default 15, 0 = no pump protection)
- 12 ΔT for sequence control (5 ... 25, default 15) resolution 0.1 K
- 13 $\Delta T1$ for pump switch heater 1 (5 .. 15 K, default 5 K)
- 14 $\Delta T1$ for pump switch heater 2 (5 .. 15 K, default 5 K)

Further information available in product manual for OT box RAMSES top2 OT at www.theben.de.

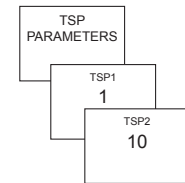

Set heating curve of second heating circuit on controller

The heating circuit is adjusted in the SETTINGS menu. On the room thermostat RAMSES 850 top2 OT the heating curve for 2 heating circuits can be adjusted (see RAMSES 850 top2 OT operating guide, page 31). Base point2 and end point2, etc. must be set on the room thermostat.

Setting range: Base point 10–30 °C, default 20 °C
End point 25-60 °C, default 35 °C

Systems/Applications 1–5

- For the systems or applications 1-4 the OT-Box RAMSES 850 top2 OT is required. The OpenTherm bus links RAMSES 850 top2 OT with the OT box RAMSES top2 OT.
- System 5 requires 2 OT boxes (centre box and end box),

which are linked via the OpenTherm bus. RAMSES 850 top2 OT as well as both boxes are linked with one another via the OpenTherm bus. The centre box must be linked to the 0–10 V (terminal 15 - 15) input with a wire bridge.

With the RAMSES 856 top2 OT an additional OT box (standard box 9070712) will be required for this system.

GB

RAMSES 850 top2 OT with 2-wire connection to 1 box

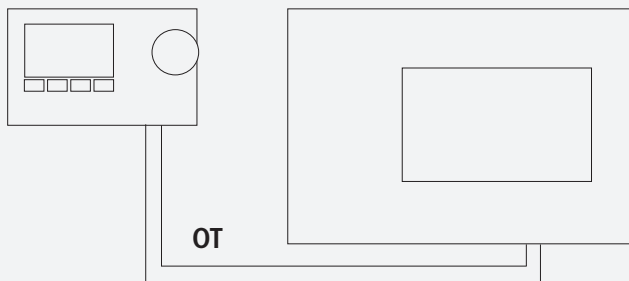

RAMSES 850 top2 OT with 2-wire connection to 2 boxes

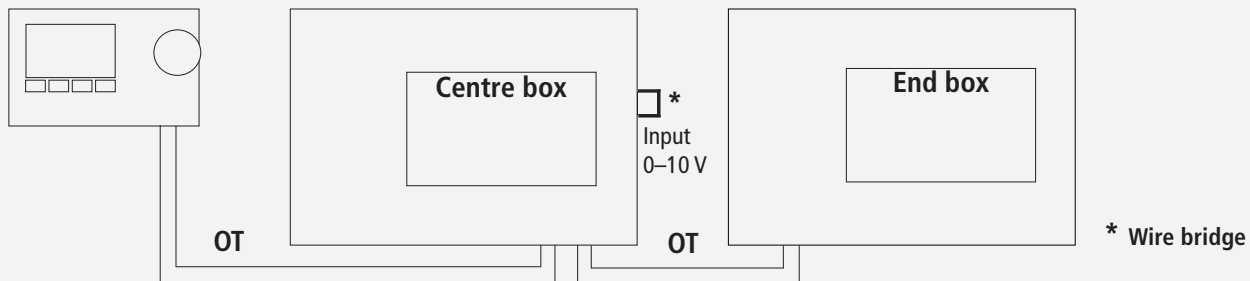

System 1

System 1 consists of a maximum of:

- Burner
- Heating circuit without mixer
- Heating circuit with mixer
- Water storage tank
- Domestic hot water circulation pump (Domestic hot water return pump)

The individual functions are activated by connecting the appropriate sensor, i.e. the domestic hot water program is only executed when the domestic hot water temperature sensor is connected.

Power connection ①

Input configuration

- Domestic hot water temperature ⑩
- Feed temperature heating circuit 2 ⑰
- Boiler temperature ⑱
- Outdoor temperature ⑲
- Domestic hot water return temperature ⑳

Output configuration

- Heating circuit pump Heating circuit 1 ⑧
- Heating circuit pump Heating circuit 2 ⑦
- Burner ⑥
- Mixer + ⑤
- Mixer - ④
- Domestic hot water feed pump ③
- Domestic hot water circulation pump ②

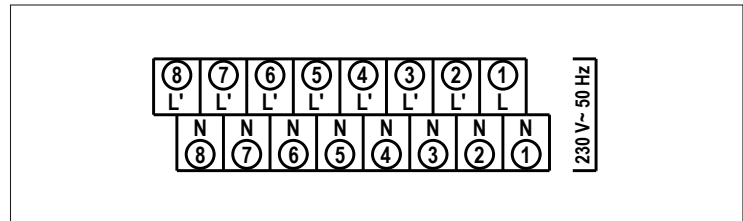
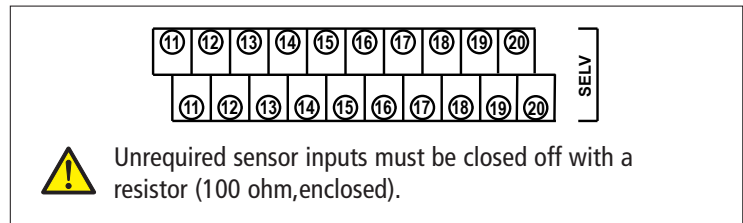
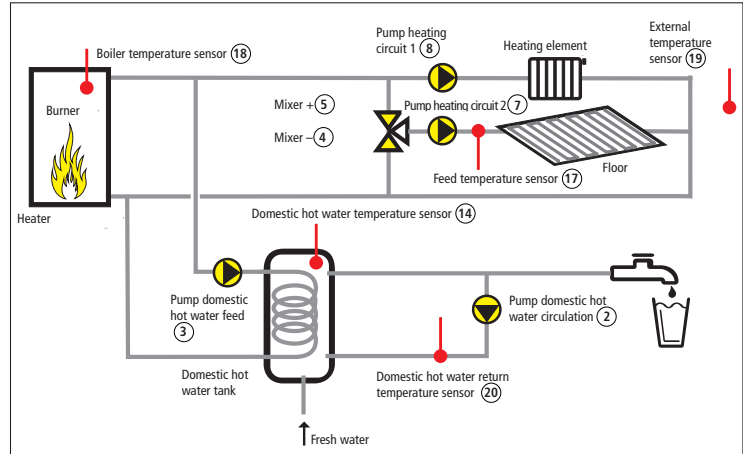

System 2

System 2 (not for AT-dependent control) consists of a maximum of:

- Burner with 2 stages
- Heating circuit without mixer
- Water storage tank
- Domestic hot water circulation pump (Domestic hot water return pump)

The individual functions are activated by connecting the appropriate sensor, i.e. the domestic hot water program is only executed when the domestic hot water temperature sensor is connected.

Power connection ①

Input configuration

- Domestic hot water temperature ⑩
- Boiler temperature ⑱
- Outdoor temperature ⑲
- Domestic hot water return temperature ⑳

Output configuration

- Heating circuit pump Heating circuit 1 ⑧
- Burner Stage 1 ⑤
- Burner Stage 2 ④
- Domestic hot water feed pump ③
- Domestic hot water circulation pump ②

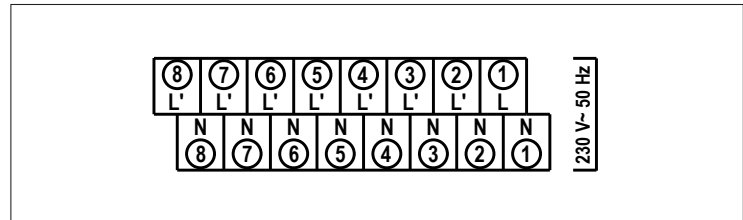
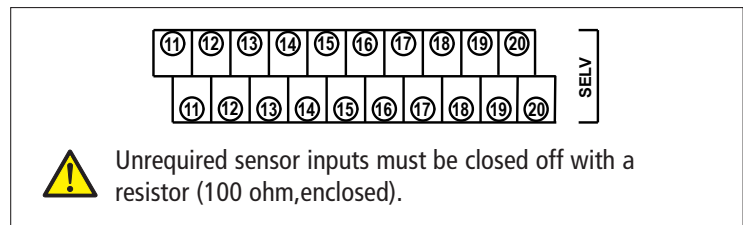
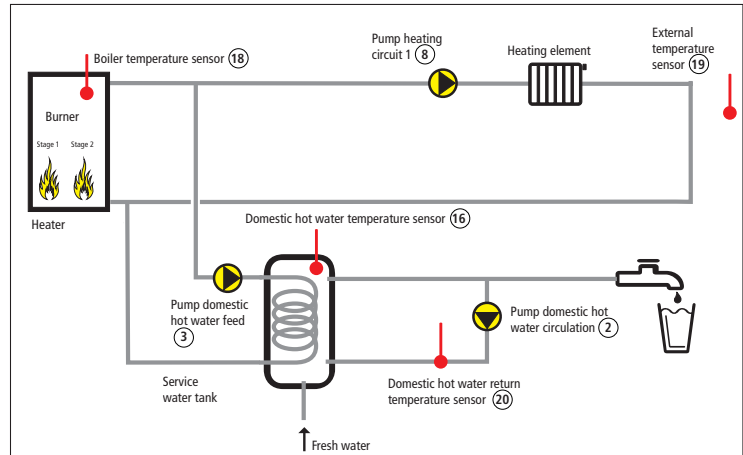

System 3

System 3 consists of:

- Burner
- Heating circuit without mixer
- 2. Heater (e.g. solid fuel boiler)
- Buffer storage
- Water storage tank
- Domestic hot water circulation pump (Domestic hot water return pump)

The individual functions are activated by connecting the appropriate sensor, i.e. the domestic hot water program is only executed when the domestic hot water temperature sensor is connected.

Power connection ①

Input configuration

- Domestic hot water temperature ⑩
- Feed temperature heating circuit 2 ⑪
- Boiler temperature ⑱
- Outdoor temperature ⑲
- Domestic hot water return temperature ⑳

Output configuration

- Heating circuit pump Heating circuit 1 ⑧
- Burner ⑥
- Pump 2. Heater ⑤
- Boiler pump (buffer storage feed pump) ④
- Domestic hot water feed pump ③
- Domestic hot water circulation pump ②

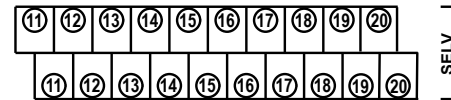
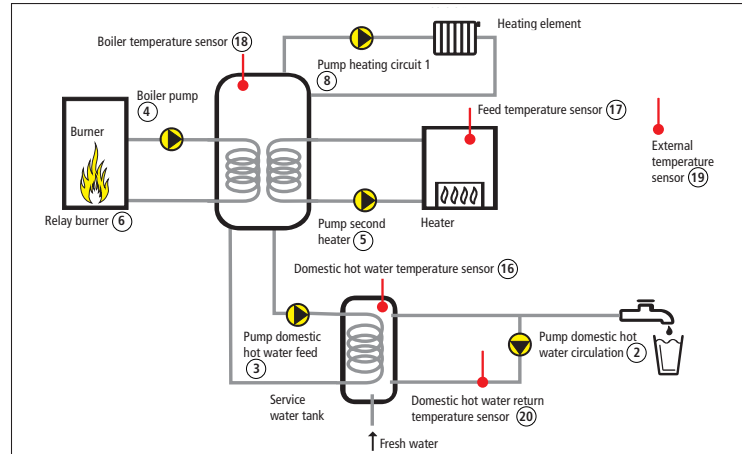

Unrequired sensor inputs must be closed off with a resistor (100 ohm, enclosed).

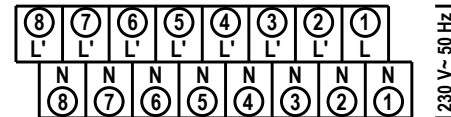

System 4

System 4 consists of:

- Burner
- Heating circuit with mixer
- 2. Heater (e.g. solid fuel boiler)
- Buffer storage
- Water storage tank
- Domestic hot water circulation pump (Domestic hot water return pump)

The individual functions are activated by connecting the appropriate sensor, i.e. the domestic hot water program is only executed when the domestic hot water temperature sensor is connected.

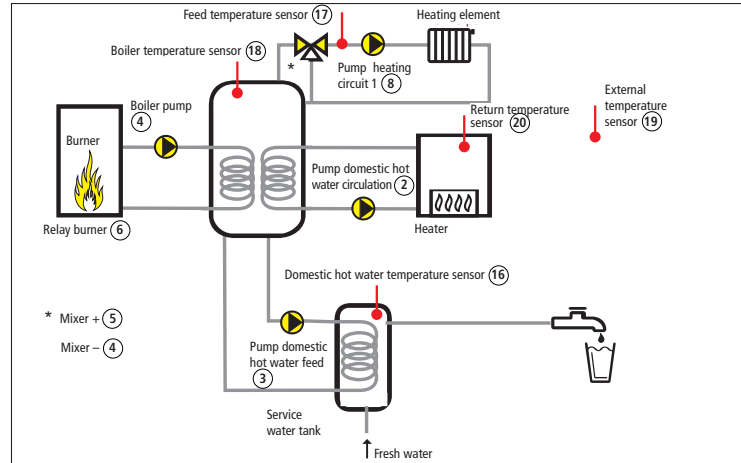

Power connection ①

Input configuration

- Domestic hot water temperature ⑩⑥
- Feed temperature ⑩⑦
- Buffer storage temperature ⑩⑧
- Outdoor temperature ⑩⑨
- Temperature 2. Heater ⑩⑩

Output configuration

- Heating circuit pump Heating circuit 1 ⑧⑧
- Boiler pump ⑦⑦
- Burner ⑥⑥
- Mixer + ⑤⑤
- Mixer - ④④
- Domestic hot water feed pump ③③
- Domestic hot water circulation pump ②②

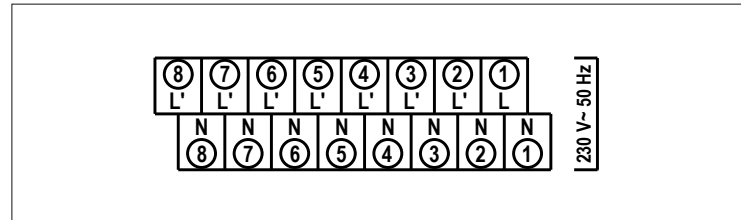
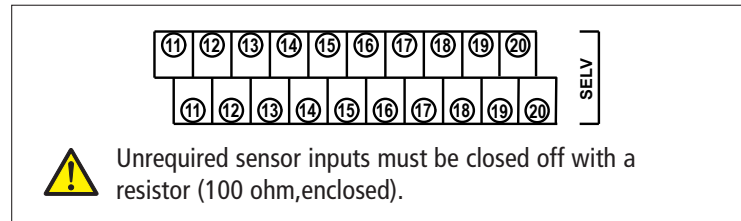

System 5 – comfort box

The Comfort box consists of RAMSES 850 top2 OT and 2 standard boxes (centre box and end box).

With it additional inputs/outputs are available for the connection of pumps, etc. Standard box (without RAMSES 850 top2 OT) can be obtained from Theben.

With the RAMSES 856 top2 OT an additional OT box (standard box 9070712) will be required for this system.

- On the centre box attach wire bridge to input 0–10 V (terminal 15 – 15) (see figure).

System 5 consists of:

- Burner
- Heating circuit 1 with mixer
- Heating circuit 2 with mixer
- 2. Heater (e.g. solid fuel boiler)
- Buffer storage
- Water storage tank
- Domestic hot water circulation pump (Domestic hot water return pump)

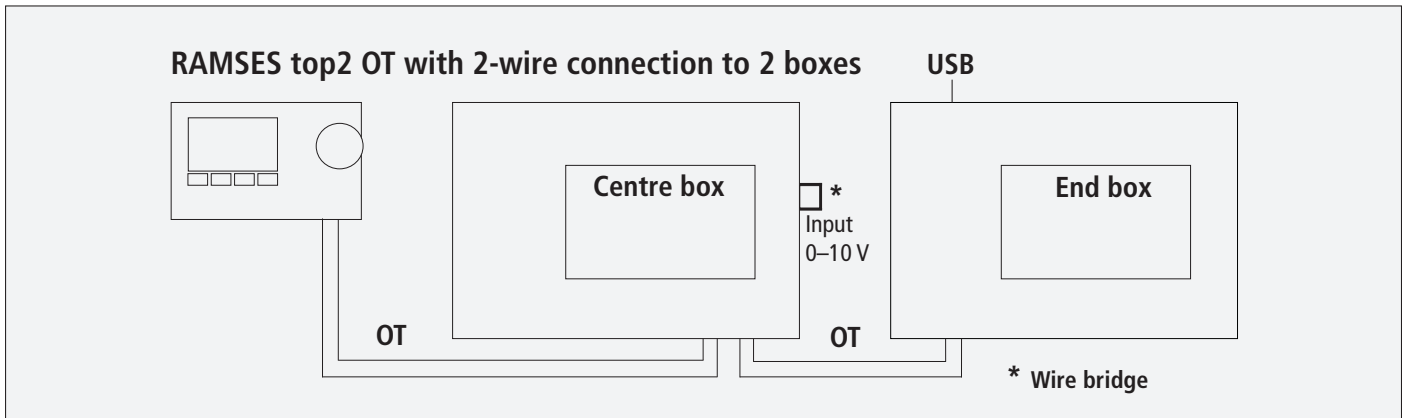

Centre box

Power connection ①

Input configuration

- RAMSES 850 top2 OT ⑬
- End box OT ⑭
- Wire bridge ⑮
- Buffer tank temperature top ⑯
- Feed temperature heating circuit 2 ⑰
- Temperature 2. Heater ⑱
- Lower buffer storage temperature ⑳

Output configuration

- Boiler pump
(feed pump buffer storage) ⑥
- Mixer + Heating circuit 2 ⑤
- Mixer – Heating circuit 2 ④
- Pump 2. Heater ③

End box

Power connection①

Input configuration

- Domestic hot water temperature ⑯
- Feed temperature heating circuit 1 ⑰
- Boiler temperature ⑱
- Outdoor temperature ⑲
- Domestic hot water return temperature ⑳

Output configuration

- Heating circuit pump Heating circuit 1 ⑧
- Heating circuit pump Heating circuit 2 ⑦
- Burner ⑥
- Mixer + Heating circuit 1 ⑤
- Mixer – Heating circuit 1 ④
- Domestic hot water feed pump ③
- Domestic hot water circulation pump ②

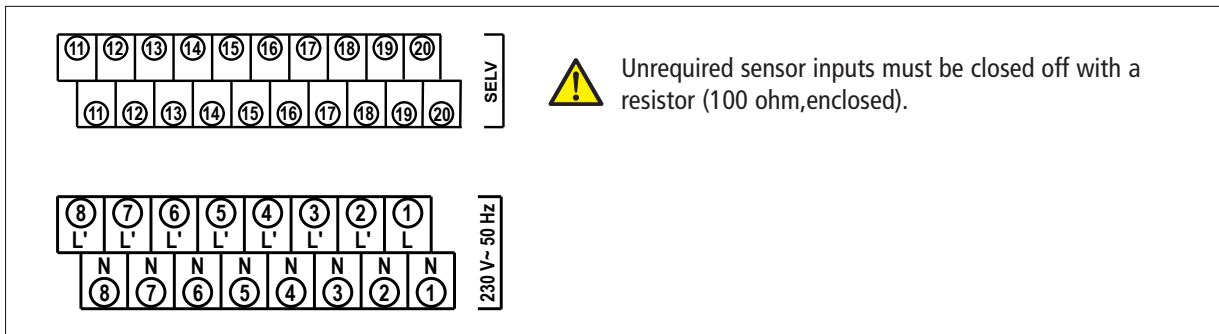

System 5

Comfort box
with centre box
and end box

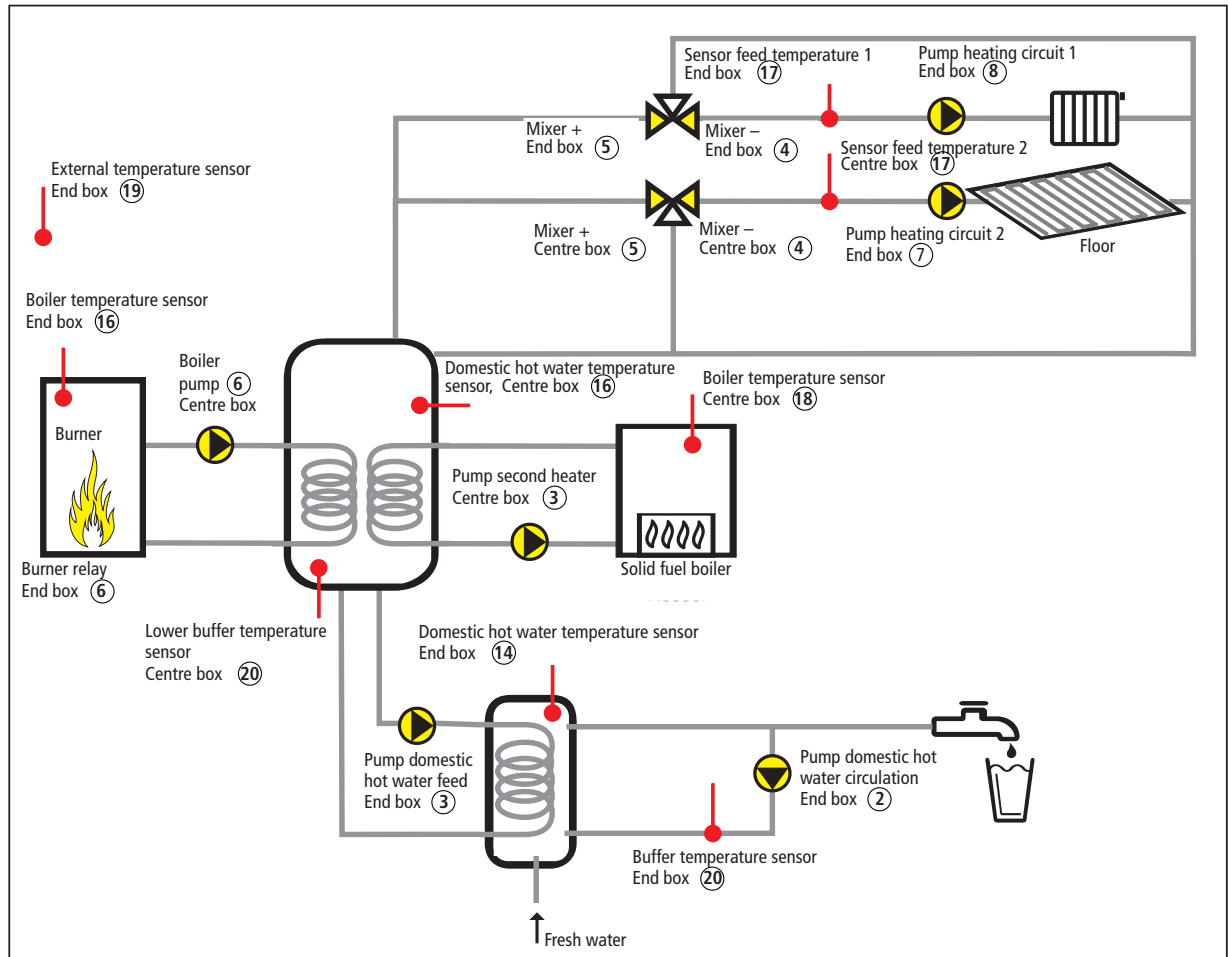

Switch chimney sweep function on/off

- Press button  on the OT-Box RAMSES top2 OT x 1. The LED lights up. The chimney sweep function (burner + pump, for measurement of emissions by the chimney sweep) is on (full load).
- Press button again; the function is switched off. If not switched off manually the chimney sweeping function ends automatically after 30 mins.

In the RAMSES 850 top2 OT, the chimney sweeping function can also be switched on and off in the SETTINGS – CHIMNEY SWEEPING.

Operating hours counter

The values burner start and burner hours are determined in the OT box and displayed on the RAMSES 850 top2 OT.

- Press INFO button. The display shows

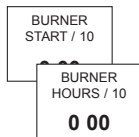

Connect USB/GSM modem

In the **SETTINGS** menu the additional sub-menu **PIN CODE** appears.

- To protect the system, enter the four-digit code of the SIM card.

Operation via SMS

When you connect a USB/GSM modem to the OT-Box RAMSES top2 OT, the desired temperature/operating mode can be set via mobile phone.

1. Room-dependent control

- To change the set point value, PIN number and temperature via SMS send to the USB/GSM modem: e.g. **PIN:1234 Set:21.0** (note format!!)
The USB/GSM modem sends an SMS with:
PIN:Ok Set:21.0 Temp:19.0
- To query the current temperature and settings, send the PIN number to the USB/GSM modem: e.g. **PIN:1234**
The USB/GSM modem sends an SMS with:
PIN: OK Set:21.0 Temp:19.0

When you receive **PIN:xxxx Set:xx,x** via SMS,

- Replace the x with the correct PIN code/desired temperature.

2. Weather-dependent control

With the weather-dependent control, you can select the operating mode by SMS.

- Send the PIN number and operating mode via SMS to the USB/GSM modem: e.g. **PIN:1234 Set:2**
 - 1 = Frost protection mode
 - 2 = Reduced mode
 - 3 = Comfort mode

The USB/GSM modem sends an SMS with the set operating mode and current room temperature:

PIN: OK Set:2 Temp:19.0

- To query the current temperature and settings, send the PIN number to the USB/GSM modem: e.g. **PIN:1234**

The USB/GSM modem sends an SMS with:
PIN: OK Set:2 Temp:19.0

When you receive **PIN:xxxx Set:x** via SMS,

- Replace the x with the correct PIN code/desired operating mode.

Error messages

If an error occurs during the adjustment, error codes appear in the RAMSES 850 top2 OT display. Error codes 20-28 originate with a sensor error.

Error-code	Error
11	11 NO COMMUNICATION
20	20 EXTERNAL TEMPERATURE ERROR
21	21 FEED ERROR 1
22	22 DOMESTIC HOT WATER ERROR
23	21 FEED ERROR 2
24	24 DOMESTIC HOT WATER RETURN ERROR
25	25 BOILER ERROR 1
26	25 BOILER ERROR 2
27	27 STORAGE ERROR 1
28	27 STORAGE ERROR 2
29	29 EXTERNAL FAULT ERROR
30	---
31	31 MODEM ERROR

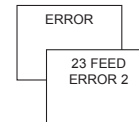

Technical data

- Operating voltage: 230 V~, +10/–15 %
- Frequency: 50 Hz
- Power consumption: typically 2.7 VA
- Standby: typically 1.1 W
- Switch load: **Relay:** 5 x max. 2 (1) A 230 V~
(burner, mixer open, mixer closed, domestic hot water pump, domestic hot water return pump)
Relay: 2 x 1 A (1 A)
230 V ~
(Heat pump 1, Heat pump 2)
- SELV power circuits:
 - Sensor inputs
 - OT (communication interface)
 - USB (data communications interface)
- Contact material: AgNi
- Contact: 7 x simple working contact
(normally open)
- Permissible ambient temperature: 0 °C to +50 °C
- Contact position for power reserve: permanently to Off
- Protection class: II in accordance with EN 60730-1
subject to designated installation
- Protection rating: IP 20 in accordance with EN 60529;
IP 65 for remote sensor

- Mode of operation: Type 1 B in accordance with
EN 60730-1
- Pollution degree: 2
- Rated impulse withstand voltage: 4 kV

A detailed manual can be found at
www.theben.de

Service address/Hotline

Service address

Theben AG

Hohenbergstr. 32

72401 Haigerloch

GERMANY

Telephone +49 7474 692 0

Fax +49 7474 692-150

Hotline

Telephone +49 7474 692 -369

Fax +49 7474 692-207

hotline@theben.de

Addresses, telephone numbers etc.

www.theben.de