

**thebenHTS**307246  
1103105101**EN** Presence detectortheRonda P360 Slave UP WH  
2080030  
theRonda P360 Slave UP GR  
2080031

## 1. Product characteristics

- Passive infrared presence detector for ceiling installation
- Circular detection area 360° to Ø 24 m (452 m<sup>2</sup>)
- Restriction of detection area with cover clips
- Detection sensitivity configurable
- Ready for immediate use due to factory presetting
- Test mode for checking function and detection area
- Extension of detection area via master/slave switching, a maximum of 10 detectors can be switched in parallel with each other
- Ceiling installation in flush-mounted box
- Ceiling installation possible with back box (optional)
- Management remote control SendoPro (optional)
- Installation remote control theSenda P (optional)

## 2. Safety

**WARNING****Danger of death through electric shock or fire!**

- Installation should only be carried out by a professional electrician!

- Work on electrical systems may only be carried out by electricians or by instructed persons under the leadership and supervision of an electrician in accordance with the technical regulations applying to electricity!
- Comply with the country-specific safety regulations for work on electrical systems! Ensure absence of voltage in the cable before installation!
- The device is maintenance-free. If the device is opened or penetrated with any objects the guarantee lapses.

## 3. Intended use

The presence detector is intended for interior installation. The presence detector is exclusively intended for the use as contractually agreed between the manufacturer and the user. Any other use is considered to be unacceptable. The manufacturer does not accept liability for any resulting damages.

## 4. Function

The slave presence detector is primarily used in offices and schools, as well as in homes, to extend the detection area. When someone is present, the presence signal is led via the P terminal to the master presence detector.

## 5. Detection area

The circular detection area of theRonda presence detector covers a large detection area, and permits a complete room coverage with many applications. Note that seated and moving persons can be detected in differently-sized areas. The recommended installation height is 2.0 m – 6.0 m. As installation height increases, the sensitivity of the presence detector decreases. Walking motions are necessary from installation heights of 3.5 m and the detection areas of several detectors should overlap in the marginal zones. The detection range is reduced as temperatures increase.

### Seated persons:

The details relate to smallest movements at table height (approx. 0.80 m).

### Moving persons:

At installation heights of between 5 and 10 m, the extent and distance between the active and passive zones increase.

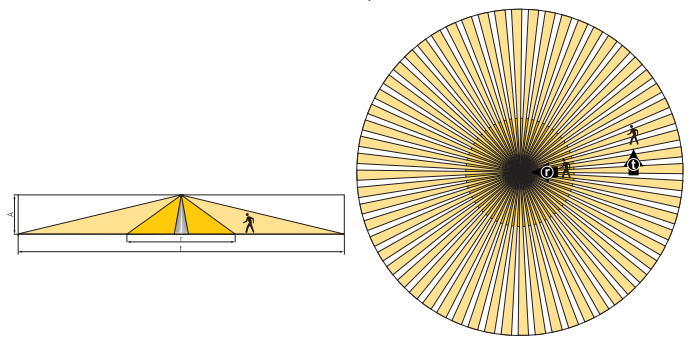

Installation height (A)	Moving persons Frontal (r)		Moving persons Across (t)		Seated persons: (s)	
	Area (m <sup>2</sup> )	Ø (m)	Area (m <sup>2</sup> )	Ø (m)	Area (m <sup>2</sup> )	Ø (m)
2,0 m	28 m <sup>2</sup>	Ø 6 m	380 m <sup>2</sup>	Ø 22 m	16 m <sup>2</sup>	Ø 4,5 m
2,5 m	38 m <sup>2</sup>	Ø 7 m	415 m <sup>2</sup>	Ø 23 m	24 m <sup>2</sup>	Ø 5,5 m
3,0 m	50 m <sup>2</sup>	Ø 8 m	452 m <sup>2</sup>	Ø 24 m	28 m <sup>2</sup>	Ø 6 m
3,5 m	50 m <sup>2</sup>	Ø 8 m	452 m <sup>2</sup>	Ø 24 m	38 m <sup>2</sup>	Ø 7 m
4,0 m	50 m <sup>2</sup>	Ø 8 m	452 m <sup>2</sup>	Ø 24 m	–	–
5,0 m	50 m <sup>2</sup>	Ø 8 m	452 m <sup>2</sup>	Ø 24 m	–	–
6,0 m	50 m <sup>2</sup>	Ø 8 m	452 m <sup>2</sup>	Ø 24 m	–	–
10,0 m	50 m <sup>2</sup>	Ø 8 m	491 m <sup>2</sup>	Ø 25 m	–	–

All figures are guidance values.

## 6. Installation

### Flush-mounted fitting

The presence detector is flush-mounted using a size 1 standard flush-mounting installation socket.

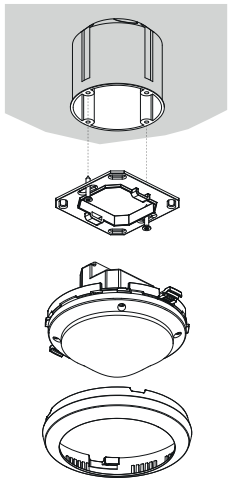

### Ceiling installation

A ceiling installation unit 73 A is available for simplified ceiling installation of the presence detector (see accessories). This also ensures cord grip and contact protection. The installation diameter is 72 mm (drill diameter 73 mm).

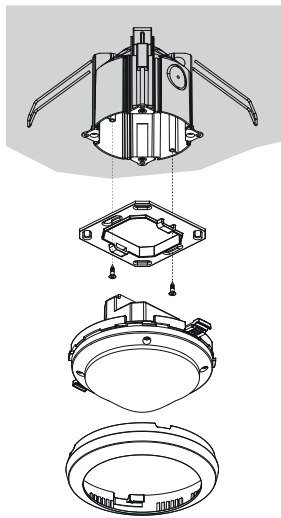

### Surface-mount installation

A back box 110A is available for surface mount installation (see accessories).

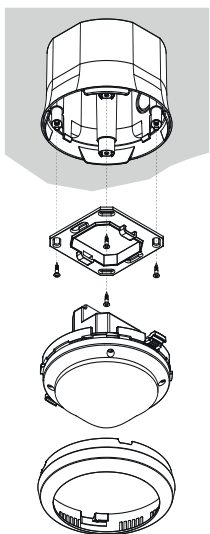

## 7. Switching

The slave presence detectors are used together with a master device in a master/slave combination.

### Master/slave parallel switching

If the detection area covered by one presence detector is insufficient (larger rooms), then up to 10 detectors can be operated in parallel by connecting P terminals. In the process, presence detection is performed by all detectors together. The master measures the brightness, operates the push buttons and controls the lighting. All other detectors are used as slaves. They only provide presence information.

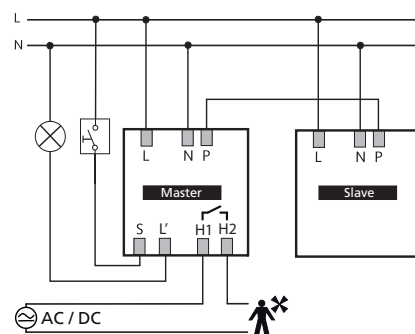
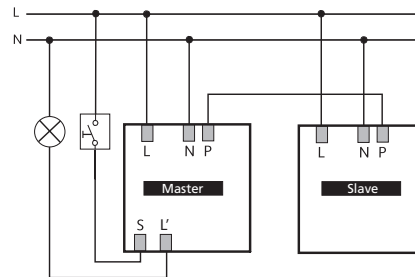

- Light measurement only with the master
- Parameters are only set on the master
- Switch up to 10 detectors in parallel
- Use the phase with the same phase for all detectors.

Master: theRonda P360 -100 M / theRonda P360-101 M  
Slave: theRonda P360 Slave

## 8. Settings

The presence detectors were supplied with basic settings ready for operation. The specifications are guidance values. The „SendoPro 868-A“ and „theSendaP“ remote controls are optionally available for start-up. They enable remote setting of all settings from a distance.

### Parameters and control commands via remote control

The following parameters can be queried or changed via the remote control for support during installation as well as servicing:

Parameter	Description	SendoPro can be queried 868-A	SendoPro be changed 868-A	theSenda P can be changed
Detection sensitivity (PIR)	Value range in levels		x	x
LED display movement	Off / On		x	

The parameters are sent to the presence detector with the „SendoPro 868-A“ management remote control or with „theSenda P“ installation remote control via infra-red. Changed parameters are immediately applied and used by the detector.

**The following control commands can be triggered with the remote control:**

Control command	Description	Can be triggered SendoPro 868-A	Can be triggered theSenda P
Presence test	On / Off	x	x
Restart	Restart detector	x	x
Factory regulations	Set all parameters and settings to factory setting.	x	

## Detection sensitivity

The detector has 5 sensitivity increments. The basic setting is the middle level (3). By selecting the operation mode test presence, the set sensitivity increment is not changed. With the „SendoPro 868-A“ management remote control, levels 1 to 5 can be selected and sent to the detector. With the „theSenda P“ installation remote control, the sensitivity can be reduced or increased by one level with every button press.

Level	Sensitivity
1	very insensitive
2	insensitive
3	Standard
4	sensitive
5	very sensitive

## LED display motion

The motion detection can be displayed via the LED.

### Value range

No display of motion detection.	Off
The LED switches on when motion is detected, otherwise switches off.	On

Adjustment possible only with „SendoPro 868-A“.

## Factory settings

The theRonda P360 Slave presence detector is supplied with the following parameter values:

Parameter	Value
Detection sensitivity (PIR)	Stage 3
LED display movement	Off

## 9. Start-up

### Switching behaviour

Every time the power supply is switched on, the presence detector runs through two phases that are shown on an LED:

#### 1. Start-up phase (30 s)

- The red LED flashes every second.
- The detector does not react to remote control commands.

#### 2. Mode

The detector is ready for operation (LED off).

### Test presence

Presence test mode is used to test presence detection and wiring. Presence test mode can be activated with the „SendoPro 868-A“ management remote control and with the „theSenda P“ installation remote control.

#### Setting the presence test mode via remote control

The detector goes directly into test mode when the test mode is set via the remote control:

- Every movement is indicated by the LED.
- Test mode ends automatically after 10 mins. The detector performs a new start (see switch-on behaviour).

## 10. Technical data

Operating voltage	110-230 V AC + 10 % / - 15%
Frequency	50-60 Hz
Upstream protection device:	13 A
Power consumption	approx. 0.1 W
Type of installation	Ceiling installation; Flush / surface mounted or ceiling installation
Installation height	2,0 – 3,5 m / max. 10 m
Minimum height	> 1.7 m
Detection area horizontal vertical	360° 120°
Maximum range	Ø 8 m (Mh. 3 m) / 50 m <sup>2</sup> radially moving Ø 24 m (Mh. 3 m) / 452 m <sup>2</sup> tangentially moving
Connection type	Terminals screws
Max. cable cross-section	max. 2 x 2.5 mm <sup>2</sup>
Flush-mounted socket size	Siz. 1, Ø 55 mm (NIS, PMI)
Protection rating	IP 54 (installed)
Ambient temperature	-15 °C – 50 °C
CE Declaration of Conformity	This device conforms to the safety regulations of the EMC directive 2014/30/EU and of 2014/35/EU.

### Product overview

Type of installation	Channel	Operating voltage	Colour	Type	Item No.
Ceiling installation	–	110-230 V AC	White	theRonda P360 Slave	2080030
Ceiling installation	–	110-230 V AC	Grey	theRonda P360 Slave	2080031

Ceiling installation	–	110-230 V AC	Special colour in accordance with customer information	theRonda P360 Slave	2080033
----------------------	---	--------------	--	---------------------	---------

## Troubleshooting

Fault	Cause
Device does not respond	Short circuit or several phases in parallel switching! Disconnect detector from the power supply for 5 mins. (thermal fuse)
Error flashing (4 x per second)	Error in self-test; Device not properly functional!

## LED display

LED	Description
Blinking in 1 second cycle	The presence detector is in the start-up phase.
Flickering for 2 s	The command sent from the remote control via infrared was accepted by the presence detector.
Lights up briefly	The command sent from the remote control via infrared was rejected by the presence detector. The command is not valid. Check the detector type or parameter selected in the SendoPro.
Fast blinking	Error blinking; The presence detector has found an error.
Lights or flickers irregularly	The presence detector is in presence test mode or "LED display movement" is activated. The LED displays detection of movement.

## Guarantee

Theben HTS presence detectors are manufactured with the utmost care and using state-of-the-art technology and are quality-tested. Theben HTS AG therefore guarantees perfect operation when used correctly. Should a fault occur, however, Theben HTS AG will fulfil the guarantee within the scope of the general terms and conditions.

Please note in particular:

- that the guarantee period lasts 24 months from the date of manufacture.
- that the guarantee is invalidated if you, or a third party, make changes or undertake repairs to the devices.
- that, insofar as the presence detectors are connected to a software-controlled system, the guarantee for this connection is only valid when the indicated interface specification is complied with.

We undertake to repair or place as quickly as possible all components of the delivered device that have become defective or unusable through demonstrably poor material, faulty construction or incomplete delivery up to the end of the guarantee period.

## Returns

In the event of a guarantee claim, please return the device to the relevant dealer together with the delivery note and a brief description of the fault.

## Industrial property rights

The design as well as hardware and software of these devices are protected by copyright.

## Dimensional drawings

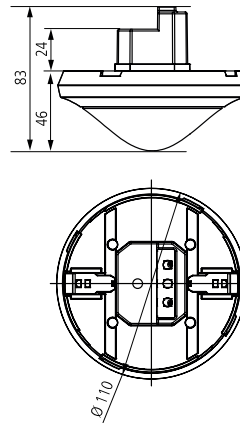

## 11. Accessories

Back box 110A WH

Item No.: 9070912

[Details > www.theben.de](http://www.theben.de)



Back box 110A GR

Item No.: 9070913

[Details > www.theben.de](http://www.theben.de)

DE (ceiling installation) box 73A

Item No.: 9070917

[Details > www.theben.de](http://www.theben.de)



Covering clip for area restriction

Item No.: 9070921

[Details > www.theben.de](http://www.theben.de)

SendoPro 868-A  
Item No.: 9070675  
[Details > www.theben.de](http://www.theben.de)



theSenda P  
Item No.: 9070910  
[Details > www.theben.de](http://www.theben.de)



## 12. Contact

Theben HTS AG  
Im Langhag 7b  
8307 Effretikon  
SWITZERLAND  
Phone +41 52 355 17 00  
Fax +41 52 355 17 01

Hotline  
Phone +41 52 355 17 27  
[hotline@theben-hts.ch](mailto:hotline@theben-hts.ch)  
[www.theben-hts.ch](http://www.theben-hts.ch)

### All countries except Switzerland

Theben AG  
Hohenbergstraße 32  
72401 Haigerloch  
GERMANY  
Phone: +49 7474 692-0  
Fax: +49 7474 692-150

Hotline  
Phone: +49 7474 692-369  
[hotline@theben.de](mailto:hotline@theben.de)  
[www.theben.de](http://www.theben.de)